

# LIVE MIXING CONSOLE **M-400**

## MIXING CONSOLE **M-380**

### RS-232C Reference Version 1.4

#### Table of contents

<b>Introduction.....</b>	<b>2</b>	Request commands.....	16
<b>Setup .....</b>	<b>3</b>	CNQ: Channel name request.....	16
About the RS-232C interface.....	3	PTQ: Phantom power supply request.....	16
Connector and cable .....	3	PSQ: j (phase) request.....	17
Handshaking .....	3	PGQ: Preamp gain request.....	17
Setup procedure .....	4	FLQ: Filter request.....	18
Connection with the control computer .....	4	EQQ: EQ request.....	18
Settings on the control computer .....	4	GTO: Gate request.....	19
Settings on the M-400/M-380.....	4	CPQ: Comp/limiter request.....	19
<b>Overview of commands .....</b>	<b>5</b>	AXQ: AUX send request.....	20
Overview of commands.....	5	MXQ: MATRIX send request.....	21
Protocol .....	5	PNQ: PAN request.....	21
Command syntax.....	6	MUQ: Mute request .....	22
Input parameters .....	6	FDQ: Fader request.....	22
Output parameters.....	6	SCQ: Current scene request.....	23
Cautions during use.....	6	LCQ : Request Locked Status of Console .....	23
<b>Command details .....</b>	<b>7</b>	VRQ: Version request.....	23
Channel selection parameters.....	7	Details of the reply commands.....	24
Commands sent from the control computer to the M-400/M-380 .....	7	Commands transmitted from the control computer to the M-400/M-380 .....	24
Details of commands sent from the control computer to the M-400/M-380	8	ack: Active reply .....	24
Control commands.....	8	ERR: Error .....	24
PTC: Phantom power supply on/off .....	8	Xon (11H) / Xoff (13H): Handshaking commands...24	
PSC: j (phase) on/off .....	8	Commands transmitted from the M-400/M-380 to the control computer.....	25
PGC: Preamp gain setting.....	9	ack: Active reply .....	25
FLC: Filter on/off .....	9	ERR: Error .....	25
EQC: EQ on/off.....	10	Xon (11H) / Xoff (13H): Handshaking commands...25	
GTC: Gate on/off .....	10		
CPC: Comp/limiter on/off .....	11		
AXC: AUX send setting .....	11		
MXC: MATRIX send setting.....	12		
PNC: PAN setting .....	12		
MUC: Mute on/off.....	13		
FDC: Fader level .....	13		
RFC: Relative fader level.....	14		
SCC: Scene recall.....	14		
RSC: Relative scene recall .....	14		
SSC: Scene store.....	15		
LCC : LOCK/UNLOCK the console operation .....	15		

# Introduction

---

This manual explains how you can control the M-400/M-380 via RS-232C. For details on the M-400/M-380 itself, please refer to the M-400/M-380 owner's manual. This document assumes that you have a general understanding of computers. For details on computer terminology and usage, please refer to other documentation.

Please be aware that the contents described in this document are subject to change without notice.

# Setup

## About the RS-232C interface

RS-232C is a standard serial interface. An explanation of the connections used by the M-400/M-380 is given below.

### Connector and cable

#### Connector specifications

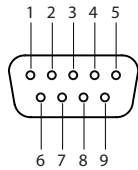

Pin number	Signal name
1	NC
2	RxD (Data In)
3	TxD (Data Out)
4	NC
5	GND
6	NC
7	Connected to pin 8
8	Connected to pin 7
9	NC

#### Cable specifications

##### RS-232C CABLE \*2

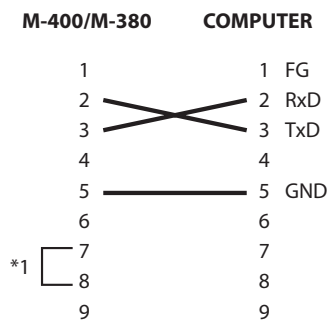

\*1: Connected internally within the M-400/M-380 (pins 7 and 8).

\*2: In order for the M-400/M-380 to operate, the three pins RXD, TXD, and GND must be connected as shown in the diagram.

## Handshaking

When data is sent from the computer and the M-400/M-380's processing speed is slower than the speed of the incoming data, something must be done to prevent part of the data from being lost. Conversely, when data is transmitted from the M-400/M-380 and the computer's processing speed is slower than the arriving data, loss of data can occur in the same way.

For this reason, the M-400/M-380 uses "Xon/Xoff" handshaking. The external computer can control the transmission from the M-400/M-380 in the same way.

"Xon": This signal is named DC1 (11H) in ASCII code; it is a control code requesting that transmission be started.

"Xoff": This signal is named DC3 (13H) in ASCII code; it is a control code requesting that transmission be stopped.

## Setup procedure

To set up the M-400/M-380 and the computer that will control it, proceed as follows.

### 1 Connect the control computer.

Use a RS-232C cable to connect your computer and the M-400/M-380.

Refer to "Connection with the control computer" (p. 4).

### 2 Power up the computer that will be controlling the M-400/M-380.

### 3 Make settings for the control computer

Perform the communication settings.

Refer to "Settings on the control computer" (p. 4).

### 4 Make settings on the M-400/M-380.

Perform the communication settings.

Refer to "Settings on the M-400/M-380" (p. 4).

### 5 Start operating the M-400/M-380.

Control computer → M-400/M-380 data transmission will begin.

## Connection with the control computer

### 1 Power off the M-400/M-380 and the computer.

### 2 On the rear panel of the M-400/M-380, set the RS-232C/MIDI switch to the RS-232C position.

### 3 Use an RS-232C cable to connect the RS-232C connector of your computer to the RS-232C connector located on the back of the M-400/M-380.

For details on the cable to use, refer to "Connector and cable" (p. 3).

## Settings on the control computer

### 1 Communication settings on the computer

Communication method	Synchronous (asynchronous), full-duplex
Communication speed	4800 / 9600 / 14400 / 31250 / 38400 / 57600 / 115200 bps You can select this as desired, but it must be the same as the setting on the M-400/M-380.
Parity	none
Data length	8 bit
Stop bit	1 bit
Code set	ASCII
XonXoff	on

\* For details on how to set the communication settings, refer to the owner's manual of the computer you're using.

## Settings on the M-400/M-380

When you power up the M-400/M-380, the communication speed will be set to 115200 bps by default.

If you're using the M-400/M-380 via RS-232C, you'll need to set its communication speed to match the setting of the computer.

For details on how to set this, refer to the M-400/M-380 owner's manual.

# Overview of commands

The M-400/M-380 and the control computer communicate via commands. There are several types of commands, and you can control the M-400/M-380 by using the command that's appropriate for your purpose.

## Overview of commands

Single-byte alphanumeric characters are used for commands.

In general, the command syntax is an ASCII string consisting of "stx" and "three uppercase letters" followed by a ";" (semicolon).

The three letters indicate the type of command. However, there are other types depending on the command. Refer to "Command syntax" (p. 6).

- \* "stx": This is the name of the signal in ASCII code (code number 02H in hexadecimal); it is a control code that indicates the beginning of a command.
- \* ";": This code lets the M-400/M-380 detect the end of the command.  
<Ex.> To transmit the \*\* command, transmit the ASCII string "stx\*\*;"

## Protocol

Depending on the command, there are two types of communication protocols between the control computer and the M-400/M-380.

### 1 When specifying an operation or setting for the M-400/M-380

This type corresponds to the "Control commands" (p. 8).

These commands use the procedure shown in the following diagram.

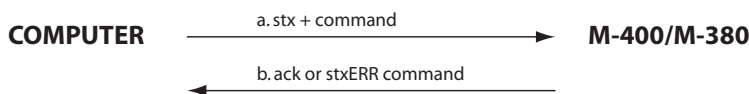

- Transmit the command from the computer to the M-400/M-380.
- The M-400/M-380 will output "ack" if the command was received correctly, or an ERR command in case of invalid reception.

- \* "ack": This is the ASCII code name of the control code (06H in hexadecimal) acknowledging successful reception.
- \* Invalid reception corresponds to cases in which the syntax of the received command was incorrect.
- \* stxERR is the command used to transmit or receive an error indication.

### 2 To learn the settings of the M-400/M-380

This type corresponds to the "Request commands" (p. 16).

Commands used to check the status of a setting in the M-400/M-380 use the following procedure.

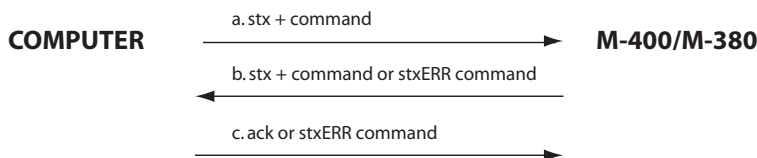

- Transmit the command from the computer to the M-400/M-380.
- If the M-400/M-380 receives the command correctly, it will send back a command containing the information that was requested. If the command was not received correctly, an ERR command will be sent back.
- If the output of the M-400/M-380 was received correctly, an "ack" will be sent back. (\* This "ack" can be omitted.)

- \* If the ERR command is sent to the M-400/M-380, the M-400/M-380 will re-transmit the command it sent in step "b." This command can also be omitted; instead of returning anything, you can repeat the procedure from step "a."

Note: The M-400/M-380 will not transmit anything when a setting is changed by a controller operation on the M-400/M-380 itself.

### Command syntax

There are several possible types of syntax for commands (control signals).

- Type 0:           Commands consisting only of a control code  
                  ";" is not added to these. They consist only of the control code.  
                  <Ex.> ack
- Type 1:           Commands that have no parameters  
                  These commands end with ";".  
                  <Ex.> stxVRQ;
- Type 2:           Commands that have parameters  
                  Command:parameter,parameter ... ;  
                  The command is separated from the parameters by a ":" (colon).  
                  Parameters are separated by a "," (comma).  
                  The end of the parameters is indicated by a ";" (semicolon).

*Note:* No spaces or tabs are allowed between commands or parameters.

### Input parameters

In general, parameters are given as decimal numbers or letters, and are of variable length.

stxFDC:I1,-25; / stxFDC:I12,0; / stxFDC:AX16,0; / stxFDC:MA,-10;

### Output parameters

Parameters are generally given in decimal or alphabetic form, and their length may vary.

stxFDS:I5,-12; / stxFDS:I24,0; / stxFDS:AX8,-6; / stxFDS:MA,-12;

### Cautions during use

Do not perform the following actions while the control computer and the M-400/M-380 are communicating. Doing so may cause the M-400/M-380 to malfunction.

- Disconnect the RS-232C cable
- Power off the M-400/M-380

# Command details

## Channel selection parameters

Some commands have a parameter that select a channel, DCA group, MUTE group, or user fader. These parameters are called the “channel selection parameter.” The relationship between the M-400/M-380’s channels and channel selection parameters are shown below.

### 1 Input channels

M-400/M-380 channels: CH1, CH2, ... CH48  
Channel Selection Parameter: I1, I2, ... I48

### 2 Output channels

M-400/M-380 channels: AUX1, AUX2,.. AUX16, MAIN L, MAIN R, MAIN C  
Channel Selection Parameter: AX1, AX2, ... AX16, MAL, MAR, MAC

### 3 MATRIX channels

M-400/M-380 channels: MTX1, MTX2, ... MTX8  
Channel Selection Parameter: MX1, MX2, ... MX8

### 4 DCA groups

M-400/M-380 groups: DCA1, DCA2, ... DCA8  
Channel Selection Parameter: DCA1, DCA2, ... DCA8

### 5 MUTE groups

M-400/M-380 groups: GROUP1, GROUP2, ... GROUP8  
Channel Selection Parameter: MG1, MG2, ... MG8

### 6 USER FADER

M-400/M-380 faders: USER1, USER2, ... USER24  
Channel Selection Parameter: U1, U2, ... U24

## Commands sent from the control computer to the M-400/M-380

The following three types of commands are sent from an external device to the M-400/M-380.

### 1 Control (execution) commands

These commands are used to adjust the volume and to make various settings.

### 2 Request commands

These commands are used to check the current state of the M-400/M-380’s settings.

\* After performing a control operation, you should use a request command to check the state of the settings.

### 3 Reply commands

Commands such as “ack” and “ERR” are in this category.

These commands are used to reply to the M-400/M-380 when a request command is used.

## Details of commands sent from the control computer to the M-400/M-380

### Control commands

#### **PTC: Phantom power supply on/off**

Function Turns the +48V phantom power supply on/off.

Syntax **stxPTC:a,b;** (Command syntax: type 2)

a: Channel selection (I1–I48, U1–U24)

b: On/off

0 (Off)

1 (On)

<Ex.> **stxPTC:I1,1;**

Turns the CH1 phantom power on.

*Note:* If you specify the following parameters, the M-400/M-380 will return an ERR command (**stxERR:5**) and will ignore your command.

- If you specify a channel that does not have phantom power.
- if you specify U1–U24 that is assigned to the above.

#### **PSC: $\varphi$ (phase) on/off**

Function Turns j (phase) on/off.

Syntax **stxPSC:a,b;** (Command syntax: type 2)

a: Channel selection (I1–I48, U1–U24)

b: On/off

0 (Off)

1 (On)

<Ex.> **stxPSC:I1,1;**

Turns the CH1 j (phase) on (inverted phase).

*Note:* If you're selecting a stereo-linked input channel, you can set this for either the L or R channel (not both).

*Note:* If you specify the following parameters, the M-400/M-380 will return an ERR command (**stxERR:5**) and will ignore your command.

- If you specify a channel outside the range of channel selections listed in the syntax.
- If you specify U1–U24 that is assigned to the above.

**PGC: Preamp gain setting**

Function Sets the pad and preamp gain of a channel.

Syntax **stxPGC:a,b,c;** (Command syntax: type 2)

a: Channel selection (I1–I48, U1–U24)

b: Pad on/off

0 (Off)

1 (On)

c: Preamp gain \*1 dB steps

-10 to -65 (with pad off)

10 to -45 (with pad on)

0 to -18 (for STEREO IN channel)

<Ex.> **stxPGC:I1,1,4;**

Turns the CH1 pad on, and sets the preamp gain to +4 dB.

*Note:* If you specify the following parameters, the M-400/M-380 will return an ERR command (**stxERR:5;**) and will ignore your command.

- If you specify a channel that has no gain adjustment.
- If you turn on the pad of a channel that has no pad.
- If you specify a GAIN of 10 to -9 for a channel whose pad is turned off.
- If you specify a GAIN of -46 to -65 for a channel whose pad is turned on.
- If you specify a GAIN setting outside the range of 0 to -18 for the STEREO IN channel.
- If you specify U1–U24 that is assigned to the above.

**FLC: Filter on/off**

Function Turns the filter on/off.

Syntax **stxFLC:a,b;** (Command syntax: type 2)

a: Channel selection (I1–I48, U1–U24)

b: On/off

0 (Off)

1 (On)

<Ex.> **stxFLC:I1,1;**

Turns the CH1 filter on.

*Note:* If you're selecting a stereo-linked input channel, you can set this for either the L or R channel (not both).

*Note:* If you specify the following parameters, the M-400/M-380 will return an ERR command (**stxERR:5;**) and will ignore your command.

- If you specify a channel outside the range of channel selections listed in the syntax.
- If you specify U1–U24 that is assigned to the above.

### **EQC: EQ on/off**

Function Turns the four-band EQ on/off.

Syntax **stxEQC:** a,b; (Command syntax: type 2)

a: Channel selection (I1–I48, AX1–AX16, MAL, MAR, MAC, U1–U24)

b: On/off

0 (Off)

1 (On)

<Ex.> **stxEQC:I1,1;**

Turns the CH1 four-band EQ on.

*Note:* If you're selecting the MAIN channel, you'll be able to set this only for L or R (not both), since the MAIN L/R channels are stereo-linked.

*Note:* If you're selecting a stereo-linked input channel or AUX channel, you can set this for either the L or R channel (not both).

*Note:* If you specify the following parameters, the M-400/M-380 will return an ERR command (**stxERR:5**) and will ignore your command.

- If you specify a channel outside the range of channel selections listed in the syntax.
- If you specify a U1–U24 that is assigned to the above.

### **GTC: Gate on/off**

Function Turns the gate on/off.

Syntax **stxGTC:** a,b; (Command syntax: type 2)

a: Channel selection (I1–I48, U1–U24)

b: On/off

0 (Off)

1 (On)

<Ex.> **stxGTC:I1,1;**

Turns the CH1 gate on.

*Note:* If you're selecting a stereo-linked input channel, you can set this for either the L or R channel (not both).

*Note:* If you specify the following parameters, the M-400/M-380 will return an ERR command (**stxERR:5**) and will ignore your command.

- If you specify a channel outside the range of channel selections listed in the syntax.
- If you are attempting to turn the gate on, and doing so would cause the gate to be on for 25 or more channels.
- If you specify U1–U24 that is assigned to the above.

**CPC: Comp/limiter on/off**

Function Turns the compressor/limiter on/off.

Syntax **stxCPC:a,b;** (Command syntax: type 2)

a: Channel selection (I1–I48, AX1–AX16, MAL, MAR, MAC, U1–U24)

b: On/off

0 (Off)

1 (On)

<Ex.> **stxCPC:I1,1;**

Turns the CH1 compressor on.

*Note:* If you're selecting the MAIN channel, you can set this for either L or R (not both), since the MAIN L/R channels are stereo-linked.

*Note:* If you're selecting a stereo-linked input channel or AUX channel, you can set this for either the L or R channel (not both).

*Note:* If you specify the following parameters, the M-400/M-380 will return an ERR command (**stxERR:5**) and will ignore your command.

- If you specify a channel outside the range of channel selections listed in the syntax.
- If you are attempting to turn on the compressor of an input channel, and doing so would cause the compressor to be on for 25 or more input channels.
- If you specify U1–U24 that is assigned to the above.

**AXC: AUX send setting**

Function Sets the AUX send level and AUX pan from CH1–48 or MAIN.

Syntax **stxAXC:a,b,c,d;** (Command syntax: type 2)

a: Channel selection (I1–I48, MAL, MAR, MAC, U1–U24)

b: AUX channel selection (AX1–AX16)

c: AUX send level (INF, -80.0–10.0) \*0.1 dB steps

d: AUX pan (L63–C–R63) \*Steps of 1

<Ex.> **stxAXC:I1,AX15,4.0,R30;**

Sets the CH1 AUX15 send level to +4.0 dBu, and the AUX pan to R30.

*Note:* If you're selecting an AUX channel, and specify an AUX channel that is not stereo-linked, the M-400/M-380 will ignore the AUX pan parameter.

*Note:* If you're selecting the MAIN channel, you can set the AUX send level for either L or R (not both), since the MAIN L/R channels are stereo-linked. AUX pan can be set individually for L and R.

*Note:* If you're selecting a stereo-linked input channel, the AUX send level can be set for either the L or R channel (not both). AUX pan can be set individually for L and R.

*Note:* If you specify the following parameters, the M-400/M-380 will return an ERR command (**stxERR:5**) and will ignore your command.

- If you specify a channel outside the range of channel selections listed in the syntax.
- If you specify U1–U24 that is assigned to the above.

### **MXC: MATRIX send setting**

Function Sets the MATRIX send level and MATRIX pan from AUX1–16 or MAIN.

Syntax **stxMXC:a,b,c,d;** (Command syntax: type 2)

a: Channel selection (AX1–AX16, MAL, MAR, MAC, U1–U24)

b: MATRIX channel selection (MX1–MX8)

c: MATRIX send level (INF, -80.0–10.0) \*0.1 dB steps

d: MATRIX pan (L63–C–R63) \*Steps of 1

<Ex.> **stxMXC: AX1,MX8,4.0,R30;**

Sets the AUX1 MATRIX8 send level to +4.0 dBu, and the MATRIX pan to R30.

*Note:* If you're selecting a MATRIX channel, and specify a MATRIX channel that is not stereo-linked, the M-400/M-380 will ignore the MATRIX pan parameter.

*Note:* If you're selecting the MAIN channel, this parameter will operate as Balance since the MAIN L/R channels are stereo-linked; you'll be able to set this for either L or R (not both).

*Note:* If you're selecting a stereo-linked AUX channel, this will operate as balance, and can be set for either the L or R channel (not both).

*Note:* If you specify the following parameters, the M-400/M-380 will return an ERR command (**stxERR:5;**) and will ignore your command.

- If you specify a channel outside the range of channel selections listed in the syntax.
- If you specify U1–U24 that is assigned to the above.

### **PNC: PAN setting**

Function Sets the pan.

Syntax **stxPNC:a,b;** (Command syntax: type 2)

a: Channel selection (I1–I48, AX1–AX16, MX1–MX8, MAL, MAR, U1–U24)

b: Pan (L63–C–R63) \*Steps of 1

<Ex.> **stxPNC:I1,L45;**

Sets the CH1 pan to L45.

*Note:* If you're selecting the MAIN channel, this parameter will operate as Balance since the MAIN L/R channels are stereo-linked; you'll be able to set this for either L or R (not both).

*Note:* If you're selecting a stereo-linked AUX channel, this will operate as balance, and can be set for either the L or R channel (not both).

*Note:* If you specify the following parameters, the M-400/M-380 will return an ERR command (**stxERR:5;**) and will ignore your command.

- If you specify a channel outside the range of channel selections listed in the syntax, or an AUX channel or MATRIX channel that is not stereo-linked.
- If you specify U1–U24 that is assigned to the above.

## **MUC: Mute on/off**

Function Switches mute on/off.

Syntax **stxMUC:a,b;** (Command syntax: type 2)

a: Channel selection (I1–I48, AX1–AX16, MX1–MX8, MAL, MAR, MAC, DCA1–DCA8, MG1–MG8, U1–U24)

b: On/off

0 (Off)

1 (On)

<Ex.> **stxMUC:I1,1;**

Turns mute on for CH1.

*Note:* If you're selecting the MAIN channel, you'll be able to set this for either L or R (not both), since the MAIN L/R channels are stereo-linked.

*Note:* If you select a stereo-linked input channel, AUX channel, or MATRIX channel, you'll be able to set this for either L or R (not both).

## **FDC: Fader level**

Function Sets the fader level.

Syntax **stxFDC:a,b;** (Command syntax: type 2)

a: Channel selection (I1–I48, AX1–AX16, MX1–MX8, MAL, MAR, MAC, DCA1–DCA8, U1–U24)

b: Fader level (INF, -80.0–10.0) \*0.1 dB steps

<Ex.> **stxFDC:I1,INF;**

Sets the CH1 fader to -Inf.

*Note:* If you're selecting the MAIN channel, you'll be able to set this for either L or R (not both), since the MAIN L/R channels are stereo-linked.

*Note:* If you select a stereo-linked input channel, AUX channel, or MATRIX channel, you'll be able to set this for either the L or R channel (not both).

*Note:* If you specify MG1–MG8 as the channel selection, the M-400/M-380 will return an ERR command (**stxERR:5**), and will ignore the command.

### **RFC: Relative fader level**

Function Sets the fader level as a relative value.

Syntax **stxRFC:a,b;** (Command syntax: type 2)

a: Channel selection (I1–I48, AX1–AX16, MX1–MX8, MAL, MAR, MAC, DCA1–DCA8, U1–U24)

b: Relative fader level (-99.9–99.9) \*0.1 dB steps

<Ex.> **stxRFC:I1,-1.0;**

Sets the CH1 fader to -1.0 dB.

*Note:* If you're selecting the MAIN channel, you'll be able to set this for either L or R (not both), since the MAIN L/R channels are stereo-linked.

*Note:* If you select a stereo-linked input channel, AUX channel, or MATRIX channel, you'll be able to set this for either the L or R channel (not both).

*Note:* If you specify the following parameters, the M-400/M-380 will return an ERR command (**stxERR:5;**) and will ignore your command.

- If you specify 0.0 as the relative fader level.
- If you specify a positive value for the relative fader level for a channel with a fader level of 10.0 dB.
- If you specify a negative value for the relative fader level for a channel with a fader level of -Inf dB.
- If you specify MG1--MG8 as the channel selection.

### **SCC: Scene recall**

Function Recalls a scene memory.

Syntax **stxSCC:a;** (Command syntax: type 2)

a: Scene number (000–299)

<Ex.> **stxSCC:010;**

Recalls scene number 010.

*Note:* If you specify a blank scene, the M-400/M-380 will return an ERR command (**stxERR:5;**) and ignore your command.

### **RSC: Relative scene recall**

Function Recalls a scene memory relatively; e.g., "the previous memory" or "two scenes ahead."

Syntax **stxRSC:a;** (Command syntax: type 2)

a: Relative scene number (-299–299)

<Ex.> **stxRSC:-3;**

Recalls the scene memory three memories earlier than the current scene number.

*Note:* If the scene memory number specified by relative scene is one of the following scenes, the M-400/M-380 will return an ERR command (**stxERR:5;**) and ignore your command.

- A blank scene.
- A scene number outside the range of 0–299.

**SSC: Scene store**

Function Stores a scene memory.

Syntax **stxSSC:** a; (Command syntax: type 2)  
**stxSSC:** a,b (Command syntax: type 2)  
**stxSSC:** a,b,c (Command syntax: type 2)

- a: Scene number (000–299)
- b: Scene name (maximum 16 characters, variable length)
- c: M-48 memory number
  - 0: Off
  - 01–16: Memory 1–16

<Ex.> **stxSSC: 010, Scene 10, 05;**

Stores current mixing parameters to scene number 010 with scene name "Scene 10".  
 Also stores connected M-48's current memory to memory number 5.

*Note:* If the scene number you specify is locked, the M-400/M-380 will return an ERR command (**stxERR: 6;**) and will ignore your command.

*Note:* If you don't specify a Scene name, the current scene name will be used.

*Note:* If you don't specify a M-48 memory number, "M-48 MEMORY" settings of the current scene will be used. You can see the "M-48 MEMORY" settings in the SCENE STORE popup on the M-400/M-380.

**LCC : LOCK/UNLOCK the console operation**

Function Lock or Unlock the console operation

Syntax **stxLCC:**a;(Command syntax : type 2)

- a: Lock/Unlock
  - 0 : UnLock
  - 1: lock

<Ex.> **stxLCC:1;**

*Note:* This command enforces to lock or unlock the console operation even in case user password is set.

The console returns ERR command and ignores the sent parameter in the following cases.

- If the console is in specified condition : stxERR:5;
- If operation cannot be locked because some operation on console is currently performed etc. : stxERR:2;

## Request commands

### **CNQ: Channel name request**

Function Requests the channel/group name.

Syntax **stxCNQ:a;** (Command syntax: type 2)

a: Channel selection (I1–I48, AX1–AX16, MX1–MX8, MAL, MAR, MAC, DCA1–DCA8, U1–U24, MG1–MG8)

<Ex.> **stxCNQ:I1;**

Requests the channel name of CH1.

### **Command returned by the M-400/M-380**

Syntax **stxCNS:a,b;** (Command syntax: type 2)

a: Channel number (I1–I48, AX1–AX16, MX1–MX8, MAL, MAR, MAC, DCA1–DCA8, U1–U24, MG1–MG8)

b: Channel name (fixed at six characters)

<Ex.> **stxCNS:I1,"A.BASS";**

Output the channel name A.BASS for CH1.

*Note:* If the channel name is blank, the output will be six spaces.

### **PTQ: Phantom power supply request**

Function Requests the on/off status of the +48V phantom power supply.

Syntax **stxPTQ:a;** (Command syntax: type 2)

a: Channel selection (I1–I48, U1–U24)

<Ex.> **stxPTQ:I1;**

Requests the on/off status of the +48V phantom power supply for CH1.

### **Command returned by the M-400/M-380**

Syntax **stxPTS:a,b;** (Command syntax: type 2)

a: Channel number (I1–I48, U1–U24)

b: On/off

0 (Off)

1 (On)

<Ex.> **stxPTS:I1,0;**

Reports that the CH1 phantom power is off.

*Note:* If you specify the following parameters, the M-400/M-380 will return an ERR command (**stxERR:5;**) and will ignore your command.

- If you specify a channel that does not have phantom power.
- If you specify U1–U24 that is assigned to the above.

**PSQ:  $\varphi$  (phase) request**

Function Requests the on/off status of j (phase).

Syntax **stxPSQ:a;** (Command syntax: type 2)

a: Channel selection (I1–I48, U1–U24)

<Ex.> **stxPSQ:I1;**

Requests the on/off status of j (phase) for CH1.

**Command returned by the M-400/M-380**

Syntax **stxPSS:a,b;** (Command syntax: type 2)

a: Channel number (I1–I48, U1–U24)

b: On/off

0 (Off)

1 (On)

<Ex.> **stxPSS:I1,0;**

Reports that the CH1 j (phase) is off.

*Note:* If you've selected a stereo-linked channel, the same value will be returned for L or R.

*Note:* If you specify the following parameters, the M-400/M-380 will return an ERR command (**stxERR:5**) and will ignore your command.

- If you specify a channel outside the range of channel selections listed in the syntax.
- If you specify U1–U24 that is assigned to the above.

**PGQ: Preamp gain request**

Function Requests the pad and preamp gain settings of a channel.

Syntax **stxPGQ:a;** (Command syntax: type 2)

a: Channel selection (I1–I48, U1–U24)

<Ex.> **stxPGQ:I1;**

Requests the pad and preamp gain settings for CH1.

**Command returned by the M-400/M-380**

Syntax **stxPGS:a,b,c;** (Command syntax: type 2)

a: Channel number (I1–I48, U1–U24)

b: Pad on/off

0 (Off)

1 (On)

c: Gain (10 to -65) \*1 dB steps

<Ex.> **stxPGS:I1,0,-55;**

Reports that the CH1 pad is off and the gain setting is -55 dB.

*Note:* If you specify a channel that has no pad, parameter "b" will return a value of "0".

*Note:* If you specify the following parameters, the M-400/M-380 will return an ERR command (**stxERR:5**) and will ignore your command.

- If you specify a channel that has no gain adjustment.
- If you specify U1–U24 that is assigned to the above.

### **FLQ: Filter request**

Function Requests the filter on/off setting.

Syntax **stxFLQ:a**; (Command syntax: type 2)

a: Channel selection (I1–I48, U1–U24)

<Ex.> **stxFLQ:I1;**

Requests the CH1 filter on/off setting.

### **Command returned by the M-400/M-380**

Syntax **stxFLS:a,b**; (Command syntax: type 2)

a: Channel number (I1–I48, U1–U24)

b: On/off

0 (Off)

1 (On)

<Ex.> **stxFLS:I1,0;**

Reports that the CH1 filter is off.

*Note:* If you select a stereo-linked input channel, the same value will be returned for L or R.

*Note:* If you specify the following parameters, the M-400/M-380 will return an ERR command (**stxERR:5**) and will ignore your command.

- If you specify a channel outside the range of channel selections listed in the syntax.
- If you specify U1–U24 that is assigned to the above.

### **EQQ: EQ request**

Function Requests the on/off setting of the four-band EQ.

Syntax **stxEQQ:a**; (Command syntax: type 2)

a: Channel selection (I1–I48, AX1–AX16, MAL, MAR, MAC, U1–U24)

<Ex.> **stxEQQ:I1;**

Requests the on/off setting of the CH1 four-band EQ.

### **Command returned by the M-400/M-380**

Syntax **stxEQS:a,b**; (Command syntax: type 2)

a: Channel number (I1–I48, AX1–AX16, MAL, MAR, MAC, U1–U24)

b: On/off

0 (Off)

1 (On)

<Ex.> **stxEQS:I1,0;**

Reports that the CH1 four-band EQ is off.

*Note:* If you're specifying the MAIN channel, you can specify either the L or R channel, since the MAIN L/R channels are stereo-linked.

*Note:* If you specify a stereo-linked input channel or AUX channel, the same value will be returned for L or R.

*Note:* If you specify the following parameters, the M-400/M-380 will return an ERR command (**stxERR:5**) and will ignore your command.

- If you specify a channel outside the range of channel selections listed in the syntax.
- If you specify U1–U24 that is assigned to the above.

**GTQ: Gate request**

Function Requests the gate on/off setting.

Syntax **stxGTQ:a;** (Command syntax: type 2)

a: Channel selection (I1–I48, U1–U24)

<Ex.> **stxGTQ:I1;**

Requests the gate on/off setting of CH1.

**Command returned by the M-400/M-380**

Syntax **stxGTS:a,b;** (Command syntax: type 2)

a: Channel number (I1–I48, U1–U24)

b: On/off

0 (Off)

1 (On)

<Ex.> **stxGTS:I1,0;**

Reports that the CH1 gate is off.

*Note:* If you specify a stereo-linked input channel, the same value will be returned for L or R.

*Note:* If you specify the following parameters, the M-400/M-380 will return an ERR command (**stxERR:5**) and will ignore your command.

- If you specify a channel outside the range of channel selections listed in the syntax.
- If you specify U1–U24 that is assigned to the above.

**CPQ: Comp/limiter request**

Function Requests the compressor/limiter on/off setting.

Syntax **stxCPQ:a;** (Command syntax: type 2)

a: Channel selection (I1–I48, AX1–AX16, MAL, MAR, MAC, U1–U24)

<Ex.> **stxCPQ:I1;**

Requests the compressor on/off setting for CH1.

**Command returned by the M-400/M-380**

Syntax **stxCPS:a,b;** (Command syntax: type 2)

a: Channel number (I1–I48, AX1–AX16, MAL, MAR, MAC, U1–U24)

b: On/off

0 (Off)

1 (On)

<Ex.> **stxCPS:I1,0;**

Reports that the CH1 compressor is off.

*Note:* If you specify the MAIN channel, the same value will be returned for L or R, since the MAIN L/R channels are stereo-linked.

*Note:* If you specify a stereo-linked input channel or AUX channel, the same value will be returned for L or R.

*Note:* If you specify the following parameters, the M-400/M-380 will return an ERR command (**stxERR:5**) and will ignore your command.

- If you specify a channel outside the range of channel selections listed in the syntax.
- If you specify U1–U24 that is assigned to the above.

### **AXQ: AUX send request**

Function Requests the AUX send level and AUX pan settings for CH1–48 or MAIN.

Syntax **stxAXQ:a,b;** (Command syntax: type 2)

a: Channel selection (I1–I48, MAL, MAR, MAC, U1–U24)

b: AUX channel selection (AX1–AX16)

<Ex.> **stxAXQ:I1,AX3;**

Requests the AUX3 send level and AUX pan setting for CH1.

### **Command returned by the M-400/M-380**

Syntax **stxAXS:a,b,c,d;** (Command syntax: type 2)

a: Channel number (I1–I48, MAL, MAR, MAC, U1–U24)

b: AUX channel number (AX1–AX16)

c: AUX send level (INF, -80.0–10.0) \*0.1 dB steps

d: AUX pan (L63–C–R63) \*Steps of 1

<Ex.> **stxAXS:I1,AX3,-6.5,C;**

Reports that for CH1, the AUX3 send level is -6.5 dB and the AUX pan is at center.

*Note:* If you select an AUX channel that is not stereo-linked, the M-400/M-380 will return "0" as the value of the AUX pan.

*Note:* If you select the MAIN channel, the same AUX send level value will be returned for L or R, since the MAIN L/R channels are stereo-linked. AUX pan can be specified individually for L and R.

*Note:* If you select a stereo-linked input channel, the same AUX send level value will be returned for both L and R. AUX pan can be requested individually for L and R.

*Note:* If you specify the following parameters, the M-400/M-380 will return an ERR command (**stxERR:5;**) and will ignore your command.

- If you specify a channel outside the range of channel selections listed in the syntax.
- If you specify U1–U24 that is assigned to the above.

**MXQ: MATRIX send request**

Function Requests the MATRIX send level and MATRIX pan settings for AUX1–16 or MAIN.

Syntax **stxMXQ:a,b;** (Command syntax: type 2)

- a: Channel selection (AX1–AX16, MAL, MAR, MAC, U1–U24)
- b: MATRIX channel selection (MX1–MX8)

<Ex.> **stxMXQ: AX1,MX3;**

Requests the MATRIX3 send level and MATRIX pan setting for AUX1.

**Command returned by the M-400/M-380**

Syntax **stxMXS:a,b,c,d;** (Command syntax: type 2)

- a: Channel number (AX1–AX16, MAL, MAR, MAC, U1–U24)
- b: MATRIX channel number (MX1–MX8)
- c: MATRIX send level (INF, -80.0–10.0) \*0.1 dB steps
- d: MATRIX pan (L63–C–R63) \*Steps of 1

<Ex.> **stxMXS: AX1,MX3,-6.5,C;**

Reports that for AUX1, the MATRIX3 send level is -6.5 dB and the MATRIX pan is at center.

*Note:* If you select a MATRIX channel that is not stereo-linked, the M-400/M-380 will return "0" as the value of the MATRIX pan.

*Note:* If you select the MAIN channel, the same MATRIX send level value will be returned for L or R, since the MAIN L/R channels are stereo-linked. MATRIX pan can be specified individually for L and R.

*Note:* If you select a stereo-linked AUX channel, the same MATRIX send level value will be returned for both L and R. MATRIX pan can be requested individually for L and R.

*Note:* If you specify the following parameters, the M-400/M-380 will return an ERR command (**stxERR:5;**) and will ignore your command.

- If you specify a channel outside the range of channel selections listed in the syntax.
- If you specify U1–U24 that is assigned to the above.

**PNQ: PAN request**

Function Requests the pan setting.

Syntax **stxPNQ:a;** (Command syntax: type 2)

- a: Channel selection (I1–I48, AX1–AX16, MX1–MX8, MAL, MAR, U1–U24)

<Ex.> **stxPNQ:I1;**

Requests the CH1 setting.

**Command returned by the M-400/M-380**

Syntax **stxPNS:a,b;** (Command syntax: type 2)

- a: Channel number (I1–I48, AX1–AX16, MX1–MX8, MAL, MAR, U1–U24)
- b: Pan (L63–C–R63) \*Steps of 1

<Ex.> **stxPNS: I1,C;**

Reports that the pan of CH1 is set at the center.

*Note:* If you specify MAIN as the channel selection, the same value will be returned for L or R, since the MAIN L/R channels are stereo-linked and this parameter is operating as Balance.

*Note:* If you specify a stereo-linked AUX channel as the channel selection, the same value will be returned for L or R, since this parameter is operating as Balance.

*Note:* If you specify the following parameters, the M-400/M-380 will return an ERR command (**stxERR:5;**) and will ignore your command.

- If you specify a channel outside the range of channel selections listed in the syntax, or an AUX channel or MATRIX channel

that is not stereo-linked.

- If you specify U1–U24 that is assigned to the above.

### **MUQ: Mute request**

Function Requests the mute on/off setting.

Syntax **stxMUQ:a;** (Command syntax: type 2)

a: Channel selection (I1–I48, AX1–AX16, MX1–MX8, MAL, MAR, MAC, DCA1–DCA8, U1–U24, MG1–MG8)

<Ex.> **stxMUQ:I1;**

Requests the CH1 mute on/off setting.

### **Command returned by the M-400/M-380**

Syntax **stxMUS:a,b;** (Command syntax: type 2)

a: Channel number (I1–I48, AX1–AX16, MX1–MX8, MAL, MAR, MAC, DCA1–DCA8, U1–U24, MG1–MG8)

b: On/off

0 (Off)

1 (On)

<Ex.> **stxMUS:I1,0;**

Reports that the CH1 mute is off.

*Note:* If you specify MAIN, the same value will be returned for L or R, since the MAIN L/R channels are stereo-linked.

*Note:* If you specify a stereo-linked input channel, AUX channel, or MATRIX channel, the same value will be returned for L or R.

### **FDQ: Fader request**

Function Requests the fader level setting.

Syntax **stxFDQ:a;** (Command syntax: type 2)

a: Channel selection (I1–I48, AX1–AX16, MX1–MX8, MAL, MAR, MAC, DCA1–DCA8, U1–U24)

<Ex.> **stxFDQ:I1;**

Requests the fader setting of CH1.

### **Command returned by the M-400/M-380**

Syntax **stxFDS:a,b;** (Command syntax: type 2)

a: Channel number (I1–I48, AX1–AX16, MX1–MX8, MAL, MAR, MAC, DCA1–DCA8, U1–U24)

b: Fader level (INF, -80.0–10.0) \*0.1 dB steps

<Ex.> **stxFDS:I1,-6.0;**

Reports that the CH1 fader level is -6.0 dB.

*Note:* If you specify MAIN, the same value will be returned for L or R, since the MAIN L/R channels are stereo-linked.

*Note:* If you specify a stereo-linked input channel, AUX channel, or MATRIX channel, the same value will be returned for L or R.

*Note:* If you specify MG1–MG8 as the channel selection, the M-400/M-380 will return an ERR command (**stxERR:5;**), and will ignore the command.

**SCQ: Current scene request**

Function Requests the number and name of the currently recalled scene.

Syntax **stxSCQ;** (Command syntax: type 1)

<Ex.> **stxSCQ;**

Requests the currently recalled scene number.

**Command returned by the M-400/M-380**

Syntax **stxSCS:a,b;** (Command syntax: type 2)

a: Scene number (000–299)

b: Scene name (maximum 16 characters, variable length)

<Ex.> **stxSCS:023,"JAZZ BAND MUSIC";**

Reports that the currently recalled scene is number 023, and that its name is JAZZ BAND MUSIC.

*Note:* If no scene memory is currently recalled, the M-400/M-380 will return an ERR command (**stxERR:5;**).

**LCQ : Request Locked Status of Console**

Function Request locked status to current operation on console

Syntax **stxLCQ;**(Command syntax : type 1)

<Ex.> **stxLCQ;**

**Command returned from the console**

Syntax **stxLCS;**(Command syntax : type 2)

a: Locked status

0: Not Locked

1: Locked

<Ex.> **stxLCS:1;**

This means the console is locked

**VRQ: Version request**

Function Requests version information.

Syntax **stxVRQ;** (Command syntax: type 1)

<Ex.> **stxVRQ;**

Requests version information for the M-400/M-380.

**Command returned by the M-400/M-380**

Syntax **stxVRS:a,b,c;** (Command syntax: type 2)

a: System version (five characters)

b: Panel version (five characters)

c: Fader version (five characters)

<Ex.> **stxVRS:1.010,1.010,1.010;**

Reports that the M-400/M-380 is using system version 1.010, panel version 1.010, and fader version 1.010.

## Details of the reply commands

### Commands transmitted from the control computer to the M-400/M-380

#### **ack: Active reply**

Function Transmitted following successful reception.

Syntax **ack (06H)** (Command syntax: type 0)

*Note:* This "ack" may be omitted.

#### **ERR: Error**

Function Transmitted when a problem occurred in the control computer in response to a command transmitted by the M-400/M-380.

Syntax **stxERR:a;** (Command syntax: type 2)

a: Error number

0 When the signal from the M-400/M-380 could not be read.

If error number 0 is returned in response to a command sent by the M-400/M-380 in response to a Request command, the M-400/M-380 will once again transmit the response to that Request command.

In the case of a command that has parameters, the M-400/M-380 will re-transmit the most recently transmitted parameter.

#### **Xon (11H) / Xoff (13H): Handshaking commands**

Function Specifies whether transmission is possible. This is used for handshaking.

Syntax **Xon (11H)** (transmission is possible) (Command syntax: type 0)

**Xoff (13H)** (transmission is not possible) (Command syntax: type 0)

## Commands transmitted from the M-400/M-380 to the control computer

### ack: Active reply

Function Transmitted following successful reception.  
Syntax **ack (06H)** (Command syntax: type 0)

### ERR: Error

Function Transmitted when a problem occurred in the M-400/M-380 in response to a command sent from the control computer.  
Syntax **stxERR:a;** (Command syntax: type 2)

a: Error number

0 (Syntax error)

Transmitted when the command syntax was incorrect.

2 (Busy error)

The M-400/M-380 is busy and cannot process the command.

5 (Out of range error)

The parameter of the received command was out of range.

6 (Other error)

Some other error has occurred. This will be transmitted if the M-400/M-380 was unable to correctly process the command.

*Note:* If one of these commands occurs, the command that was sent to the M-400/M-380 immediately prior to this will be ignored.

### Xon (11H) / Xoff (13H): Handshaking commands

Function Specifies whether transmission is possible. These are used for handshaking.  
Syntax **Xon** is **11H** only (transmission is possible)  
**Xoff** is **13H** only (transmission is not possible)